



Ethos Condensing Boilers

Wall mounted: 36kW-46kW Condensing Combination Boilers

The Ethos 36 & 46 Condensing Combination Boilers

The Ethos 36 and 46 Condensing Combination Boilers represent the very best in modern boiler technology. With domestic hot water flow rates up to nearly 22 litres per minute coupled with ultra low emissions and efficiencies (net) in excess of 100%, Ethos boilers provides an outstanding package.

For larger domestic or commercial applications, where domestic hot water storage is essential, Ethos boilers can supply an indirect hot water cylinder (Mikrofill Rapide) offering complete design flexibility.

Suitable for single or multiple installations the Ethos 36 and 46 incorporate a stainless steel heat exchanger with a fully modulating pre-mix burner suitable for natural gas or LPG.

Supplied as standard, the advanced management system with weather compensation and frost protection maintains the boiler in its most efficient (condensing) mode for as long as possible, whilst reducing running costs and 'greenhouse' gases.

As a compact room sealed appliance with a wide range of flue options for concentric or two pipe systems, accommodating flue runs of up to 30 metres, Ethos boilers offer the installer complete flexibility in boiler location.



To complete this impressive package, the Ethos 36 and 46 are housed in an attractive, durable casing with a discreet control panel offering full self-diagnostic display.

What is a Condensing Boiler?

Modern conventional boilers are efficient, but there is still a considerable amount of energy carried to waste in the flue gases, which in an average boiler will exit at around 200°C. In a condensing boiler the energy usually lost in these flue gases is reclaimed. This reclamation results in very low flue gas temperatures, so low that the water content of the flue gases condense from vapour into water, hence the term "condensing boiler". This process can result in energy savings of up to 12.5% over a conventional boiler. The process requires a boiler design that will operate reliably whilst condensing, and also a heating system that will encourage the boiler to operate in the "condensing mode". Most modern condensing boilers also feature the latest developments in combustion technology, which result in very low emissions of "greenhouse gases".

The correct use of a condensing boiler will offer considerable energy cost savings to the user, whilst minimising the emission of harmful products of combustion.

How to obtain the best results from a condensing boiler

Install the boiler into a purpose designed heating system, Mikrofill technical department can assist with this.

Electronic weather compensation ensures that the system is operated at the lowest possible temperature to maintain comfort levels, all Mikrofill condensing boilers feature weather compensation as standard. Use high recovery hot water cylinders to reduce the time that the boiler operates at maximum temperature, most Mikrofill high recovery hot water cylinders only require 20 minutes heat-up period from cold.

Balance the boiler output to the heating load, all Ethos boilers are fully modulating and automatically adjust the output of the boiler to the demand, so reducing costs.

High Efficiency

The advanced design of the premix gas burner incorporated in the Ethos range enables very precise control of the boiler output; the boiler automatically adjusts the output to suit demand. The 9:1 turn down ratio allows outputs as low as 5.4kW from the Ethos 46 (46kW max output) whilst maintaining unsurpassed efficiency and low emissions. The output is automatically controlled by the boiler, but can easily be externally controlled by use of "Open Therm" technology.

Open Therm Controls

Ethos boilers can be controlled by conventional means, i.e. time clock, room stat, outside air sensor etc, additionally the boilers incorporate "Open Therm" technology as standard, allowing the most sophisticated of control, utilising a simple "two wire" installation. This function is particularly useful when controlling multiple (modular) boiler installations.

Modular Applications

Ethos boilers are perfectly suited to modular applications. The compact design, flue options, and choice of control, coupled with the ease of installation, combine to offer an unsurpassed package; furthermore Mikrofill can assist in all aspects of modular boiler application.

Domestic Hot Water

An added advantage of the Ethos 36 & 46 is that the boiler incorporates a domestic hot water facility (up to 22 litres per minute on the Ethos 46), so for example a modular arrangement of three Ethos 46 boilers would have a maximum heating output of 126kW, but could also supply up to 66 litres per minute of domestic hot water on demand and it is possible to install a recirculation circuit to the domestic hot water circuit. The domestic hot water facility can simply be programmed off if not required.

High Standards

All Mikrofill products carry the relevant approvals; Ethos boilers have full EU gas approval, WRAS approval, are SEDBUK A rated appliances and are CE marked accordingly.



Cert No. 0201032
SEDBUK
A - Rated

The Ethos 36 & 46

Dimensions

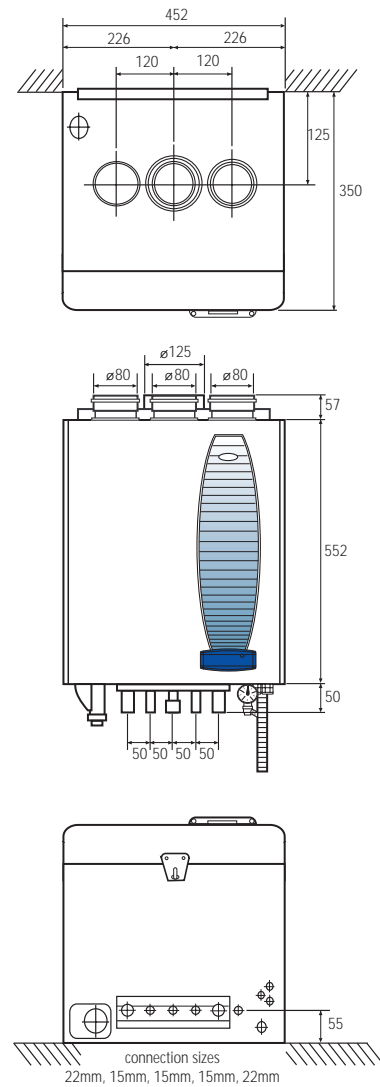

Technical Data - Ethos 36 & 46

GENERAL			
CE product ID number	CE 0063 BL 3615-2000		
Dimensions (h x w x d)	550mm x 450mm x 350mm		
Catagory	IIL2L3P		
Type of appliance		36	46
CH water content of appliance	Litre	2.1	2.7
CH water content heat exchange hot water	Litre	1.5	1.5
Weight (empty)	kg	39	41
CH connections supply/return	mm	22	22
Gas connection	mm	15	15
Hot water, hot/cold	mm	15	15
Flue gas connection	mm	80	80
Air inlet	mm	80	80
Concentric	mm	80/125	80/125
Electrical power required	kW	0.115	0.115
IP classification		IP44	IP44

CAPACITY: CH OPERATION			
Nominal load (lower value)	kW	4.3-28.5	5.4-38.7
Nominal load (upper value)	kW	4.8-31.7	6-43
Max gas use	m ³ /hour	3	4.4
Efficiency at 50/30°C, full load	%	106	106
Efficiency at 50/30°C, partial load	%	109.5	109.5
Efficiency at 40/30°C, RAL 61	%	110	110
Nominal capacity at 80/60°C	kW	4.1-27	5.3-38
Nominal capacity at 50/30°C	kW	4.6-30	5.8-42
Gas approval HR Label		107	107
NOx emissions, RAL 61	mg/kWh	<15	<15
CO emissions, RAL 61	mg/kWh	<20	<20

CAPACITY: HOT WATER			
Nominal load (lower value)	kW	4.3-36	5.4-46
Nominal load (upper value)	kW	4.8-40	6-51
Tap quantity at 60°C (ΔT=50k)	l/min	10	12.9
Tap quantity at 40°C (ΔT=30k)	l/min	17	21.4
WRAS Approval number		0204111	
Annual use efficiency for EPC calculation	%	83	82
Hot water (preset value)	°C	60	60

TECHNICAL DATA		
CO ₂ content flue gas	%	9
Dew point of the flue gas	°C	52
Temperature flue gas at 80/60 (with an ambient temperature of 20°C)	°C	75
Permitted resistance exhaust system	Pa	Up to 100
PH value of the condensate		4 to 5.5
Available CH pump pressure	kPa	15 at ΔT20°C 28 at ΔT25°C
Maximum supply temperature	°C	90
Working pressure min/max	bar	1/3
Connection pressure sanitary water min/max	bar	0.2-10
NOx-class		5
Sedbuk rating		A

Minimum Clearances

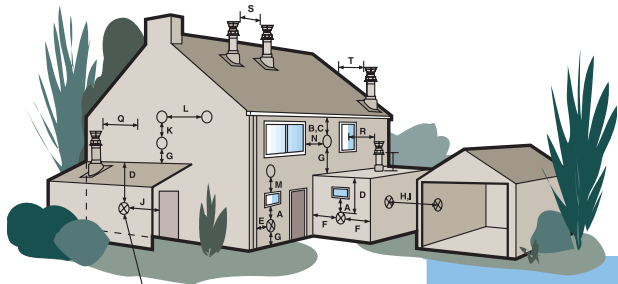

⊗ Likely flue positions requiring a flue terminal guard

BS 5440 Part1: 2000 & 2002
(BS 5440: 1990 all based on 0-60kW GROSS)

Horizontal Flues	Heat Input KW NET	ROOM SEALED		OPEN FLUE	
		NATURAL DRAUGHT mm	NATURAL DRAUGHT mm 0-60kW GROSS	FAN DRAUGHT mm	FAN DRAUGHT mm
A Directly below an openable window, air vent	0-7 7-14 14-32 32-70	300 600 1500 2000	300	300 (300)	300 (300)
B Below gutter, drain/soil pipe	0-70	300	300	75 (75)	75 (75)
C Below eaves	0-70	300	300	200 (200)	200 (200)
D Below a balcony/carport roof	0-70	600	600	200 (200)	200 (200)
E From vertical drain pipes and soil pipes	0-5 5-70	300 300	75	75 (75) 150 (75)	150 (75)
F From internal or external corners	0-70	600	600	300 (200)	200 (200)
G Above ground, roof or balcony level	0-70	300	300	300 (300)	300 (300)
H From a surface facing a terminal	0-70	600	600	600 (600)	600 (600)
I From a terminal facing a terminal	0-70	600	600	1200 (1200)	1200 (1200)
J From opening in a carport (door/window/vent) into dwelling	0-70	1200	1200	1200 (1200)	1200 (1200)
K Vertically from a terminal on the same wall	0-70	1500	1500	1500 (1500)	1500 (1500)
L Horizontally from a terminal on the same wall	0-70	300	300	300 (300)	300 (300)
M Above an opening window or air brick	0-7 7-14 14-32 32-70	300 400 600	nmg	300 (nmg)	300 (nmg)
N Horizontally beside an opening or air brick	0-7 7-14 14-32 32-70	300 600	nmg	300 (nmg)	300 (nmg)

Vertical Flues	Minimum distance to edge of terminal (mm)
P Above the roof level (to base of terminal)	300
Q From adjacent wall to flue	300
R From an adjacent opening window	1000
S From another terminal	600
T From terminal to inclined place when measured horizontally	300

Minimum Clearances - Flue Options

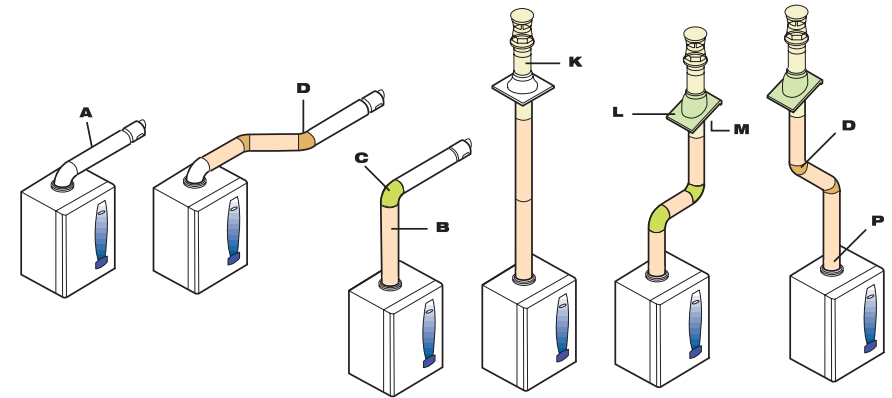

Key

Concentric Flue System 80/125mm diameter

- A** Horizontal flue Kit (including 90° elbow)
- B** Straight extension kit 1000mm
500mm
- C** Bend 90°
- D** Bend Kit 45°
- K** Vertical flue terminal
- M** Roof cover plate kit
- P** Boiler connection vertical concentric

80mm two pipe system available, contact our tech dept for details.

Flue Options

The maximum permissible flue length for each boiler is given in the technical information table.

This refers to a straight flue, a reduction in this maximum length must be made for every bend that is used in the system and the maximum length reduced by the values shown below:

Concentric pipe System

- 45° bend reduce maximum length by 0.5 metres per bend
- 90° bend reduce maximum length by 1.0 metre per bend

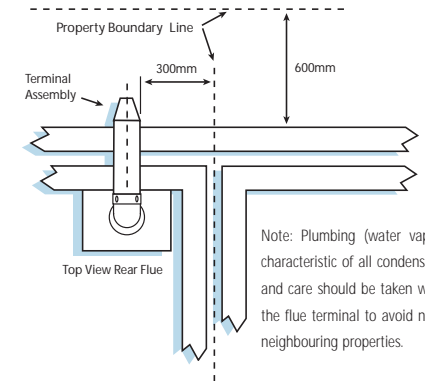

Note: Plumbing (water vapour) is a characteristic of all condensing boilers and care should be taken when siting the flue terminal to avoid nuisance to neighbouring properties.

Please refer to the latest regulations in force for confirmation and full details of flue installation.

External Connection Diagram (Schematic)

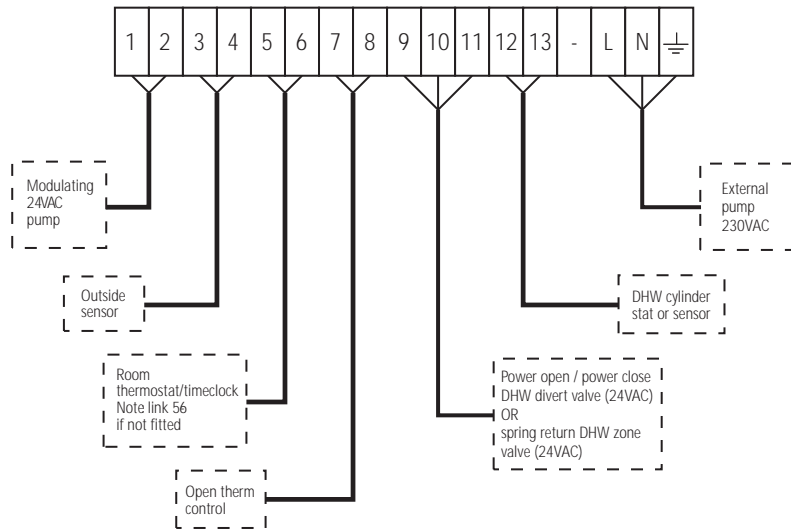

Notes:
 --- Optional
 230V/50Hz supply via flying lead

Typical System Layouts

Standard 'Combi' Schematic

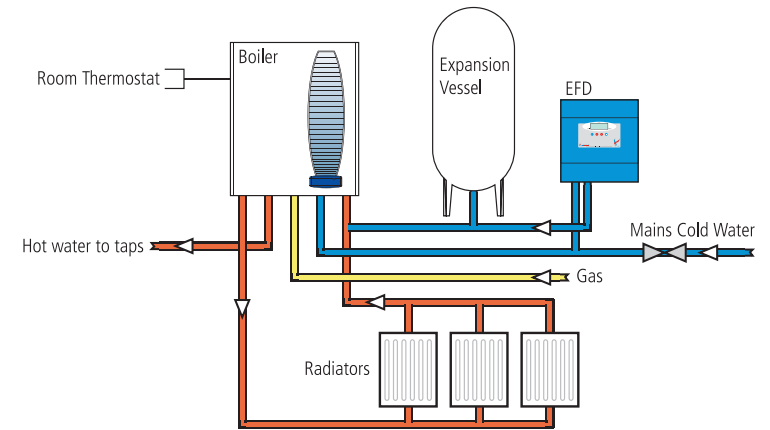

Combi with High Recovery Hot Water Cylinder

